



FREESKY
go anywhere

USER MANUAL
20" BOULEVARD ELECTRIC BIKE





FREESKY
go anywhere

YANSHAN Technology Co., LTD

**Contact us if you experience issues relating to riding
Maintenance and safety, or errors/faults with your FREESKY e-bike**

 [https:// www.freeskycycle.com](https://www.freeskycycle.com)

 Amazon& Walmart : support@freeskycycle.com

 Official Website: service@freeskycycle.com

 <https://www.youtube.com/@freeskyebike>

 <https://www.facebook.com/groups/freeskyebike>



Please register your Freesky Ebike warranty upon receiving the bikes. Registering your warranty is crucial for accessing superior customer service and support. Follow this link to register: <https://www.freeskycycle.com/pages/warranty-registration>.



BOULEVARD

Commuter e-Bike



Words to Users

Thank you for choosing Freesky! In order to make it easier for you to experience the product and be safe at riding, detailed instruction is provided, from which you can find the product's instruction, usage and other information. Before using this product, please read the manual carefully so that you can correctly use it.

Please record your bicycle's serial number in the space below. The serial number is located on the head tube of your bicycle. Refer to page 3 for the location of the serial number.

SerialNumber: _____

User Precautions	01
Package List	02
Product Overview	03
Assembly	11
Battery	13
Start-Up Procedure	15
Display	16
Before your first ride	25
Daily care and Maintenance	26
Troubleshooting	32
Specifications	33
FAQS	34
Warranty	35
Disclaimer	37
Refund policy	38



Product Safety Notice



To prevent **PROPERTY DAMAGE, SERIOUS INJURY, or DEATH**, you should read, understand, and follow the instructions below:



Always wear a helmet when riding your electric bike.



Keep the two keys properly. If the unique keys are lost, you will not be able to turn on the bike or replace the battery. If necessary, you should get more spare keys. (We don't have a backup key)



Make sure your electric bike has a full battery before taking it out to ride.



Always respect pedestrians.



Your electric bicycle can withstand light rain and small splashes, but it is not designed to be subjected to inclement weather, extremely heavy showers, or submersion in water. The electric bike's components have an IP rating of 65. Water damage is not covered under the warranty



Walk the bike in PAS 0 after the bike is powered on to avoid sudden acceleration.



When stopping the bike, **ALWAYS** apply right brake lever (rear wheel) before and during use of the front brake. **ALWAYS** apply even pressure to both brake levers when slowing down or stopping. If only the front brake is applied while slowing or stopping quickly, you may be ejected over the front handlebars.







Always be aware of local road laws, and follow them.



Package List

Carefully check package contents, if anything is missing or damaged, please contact Freesky customer service : support@freeskycycle.com

Unpack the bike. Open the bike box and remove the small box inside. With the help of another person capable of safely lifting a heavy object, remove the bike from the bike box. Carefully remove the packaging material protecting the bike frame and components. Please recycle packaging materials especially card board and foam whenever possible. Open the small box and carefully set out all contents.

 1x Electric Bike	 1x Charger	 2x Pedals
 2x Wrench 7x Allen Key Wrench	 1x User Manual	 2x Keys
 1x Saddle	 1x Skewer	 1x Fender



Product Overview





Handlebar Assembly

1



1.Insert the handlebar to the stem.

2



2.Straighten the stem and close the quick release lever.

3



3.Loosen the screw and adjust handlebar position.

4



4.Adjust the height of handlebar. Pay attention to the mini insertion mark.



Front Wheel Assembly

1. Insert the axle into the wheel hub as shown, Add the Thick Spacer on the LEFT side (Brake Disk) and the Slim Spacer on the RIGHT side.
2. Insert the front wheel with the spacers in between the front fork on the bike. Be sure to align the disk between the brake caliper as shown in Figure 2.
3. Now on the outside add the washer and nut on each side and hand turn until snug.

Figure 1

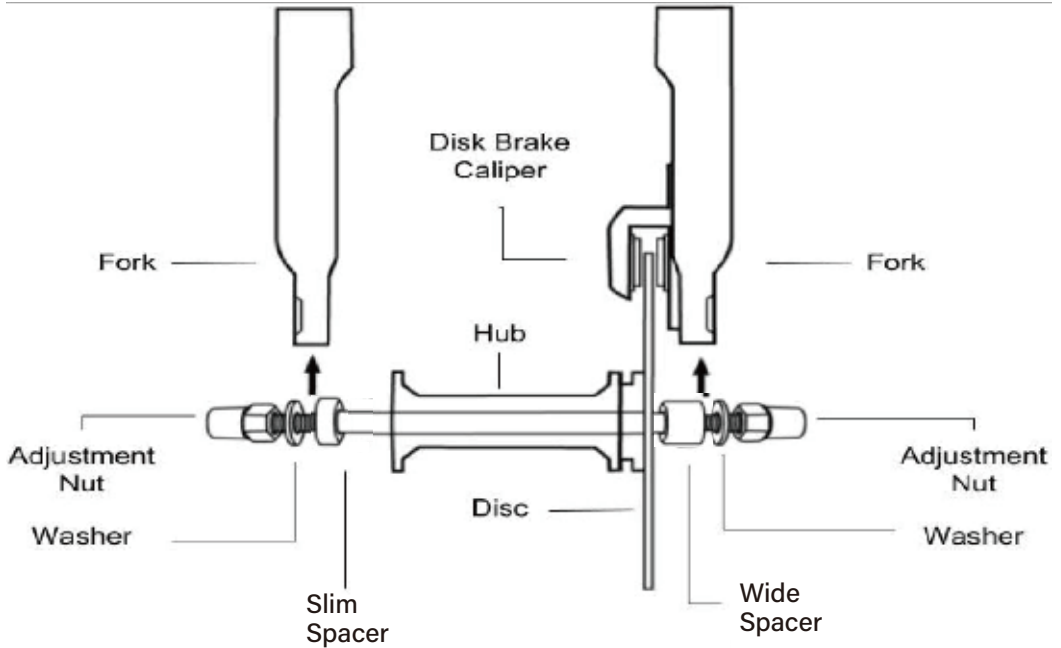

4. Using your wrench, tighten each side alternatively until snug (you might need to secure the opposite nut slightly so the whole axle doesn't turn)

Figure 2

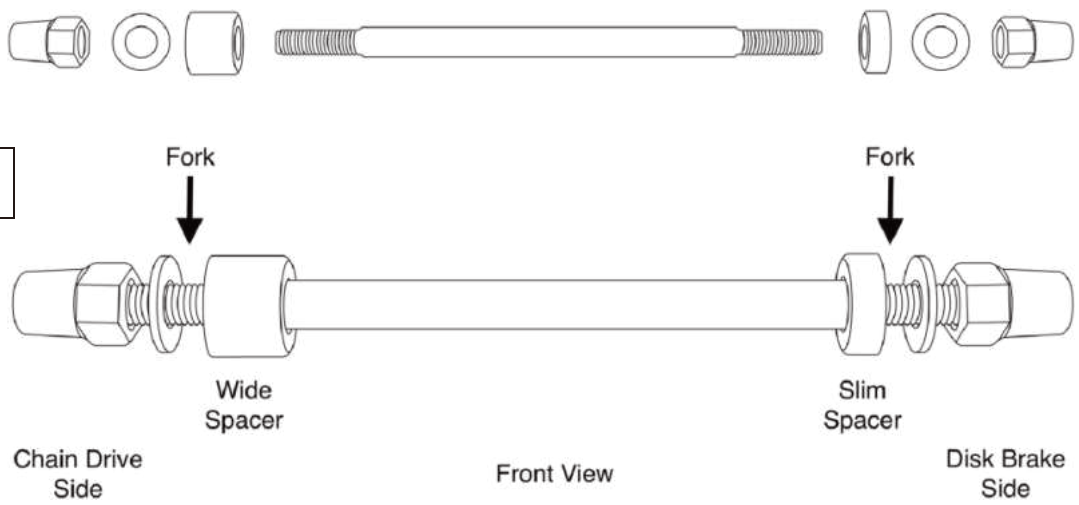

5. Now tighten each nut putting your weight into the wrench. Your front wheel is now installed.

6. The Adjustment Nut needs to be very tight, be sure to retighten after your first couple rides.



Front Light and Fender Assembly

1



1. Remove the headlight mounting hardware from the fork arch.

2



2. Pass the bolt through the headlight mount hole to tighten fender and headlight.

3



3. Connect the headlight cable and make sure the two arrows on the connector aligned.

4



4. Remove the screws on both sides of the front fork arms and then tighten the iron bar.



Saddle Assembly

For better pedaling, safety and overall riding comfort, positioning the seat at the right height is important. The rider's leg length is used to determine the seat's position. When you pedal, your hips should remain level and your legs should be almost fully extended at the bottom of the pedal stroke, but not over-extended. To determine the right seat height, sit on the e-Bike with one pedal at its lowest point and place the ball of your foot on the pedal. Your leg should be almost fully extended(not locked out) with a slight bend at the knee.

1



1. Open the quick release lever by swinging the lever open and outward fully.

2



2. Insert the seat post into the seat tube.

3



3. Tighten the securing nut.

4



4. Close the quick release lever using your palm or finger.



Seatpost Adjustment

(1) NOTICE: Ensure the seat post and seat are properly adjusted before riding. DO NOT raise the seat post beyond the minimum insertion marking etched into the seat tube (as shown on the right). If the seat post projects from the frame beyond these markings, the seat post or frame may break, which could cause a rider to lose control and fall. Ensure the minimum insertion markings on the seat post inside the seat tube of the frame.



(2) Before using the bike, always check to ensure all latches, levers, and quick releases are properly secured and undamaged. Check that they are correctly secured before every ride and after every time the bike is left unsupervised, even for a short time. Otherwise, the handlebar stem and/or seat post may come loose and can result in loss of control, damage to the bike, property, serious injury, and/or death.





Front Fork Adjustment

The suspension fork can move up and down up to 80mm to cushion bumps in the riding surface, which can make riding on a rough road or trail smoother and more comfortable.

Depending on a rider's preference, the suspension fork can be locked out as a rigid fork, which will typically yield higher efficiency while pedaling.

The lockout lever(1), located on top of the right side of the suspension fork, can be turned counterclockwise until it stops to completely lockout the suspension fork's travel. To unlock the lockout lever, turn the knob clockwise until it stops. When the lockout lever is unlocked, resistance can be adjusted by turning.

The preload adjustment knob(2), located on the top of the left side of the suspension fork. To soften the ride, subtract resistance by turning the preload adjustment knob counterclockwise, in the direction of the small "-" on the knob. To make the suspension suffer when going over bumps, add resistance by turning the preload adjustment knob clockwise, in the direction of the small "+" on the knob.





Pedals Assembly

1. **Warning:** Incorrect installation will cause damage. Please read the instructions and watch our videos if needed.
2. Identify the Left and Right markings on the pedals. They can only be installed in their respective side.
 - a. L is for the Left Pedal and it goes on the Left Crank Arm.
 - b. R is for the Right pedal and it goes on the Right Crank Arm (Chain Side)

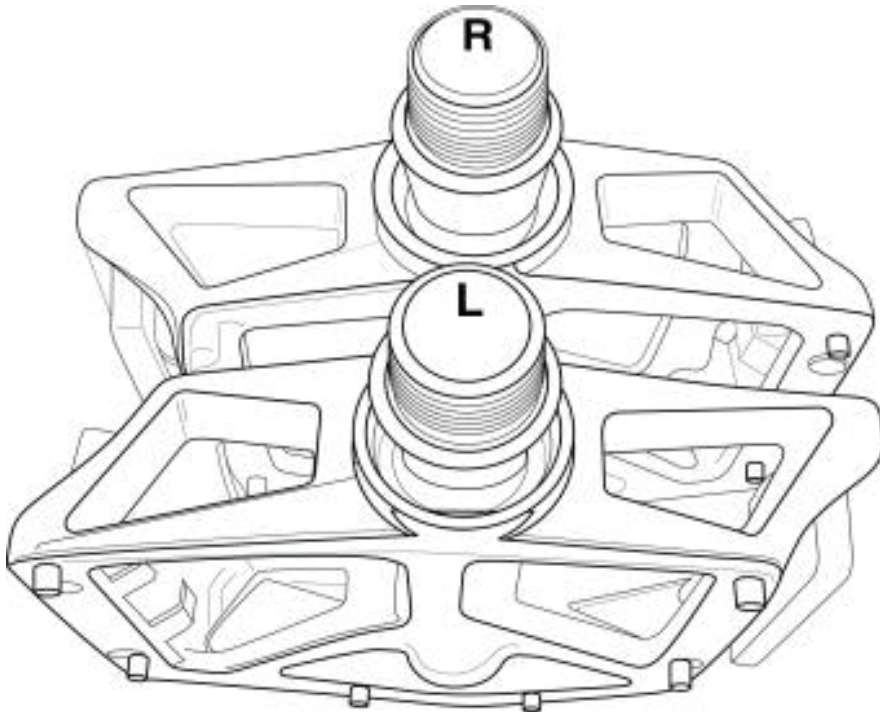

3. Sitting on your bike the pedals go on the Left and Right side respectively.
4. Keep the pedal Horizontal while hand screwing to get the thread started. Then Use your 15mm wrench to tighten them.
5. Both pedals tighten towards the front of the bike. The left pedal is reverse threaded to allow this.
6. The pedals need to be very tight, be sure to retighten after your first couple rides.

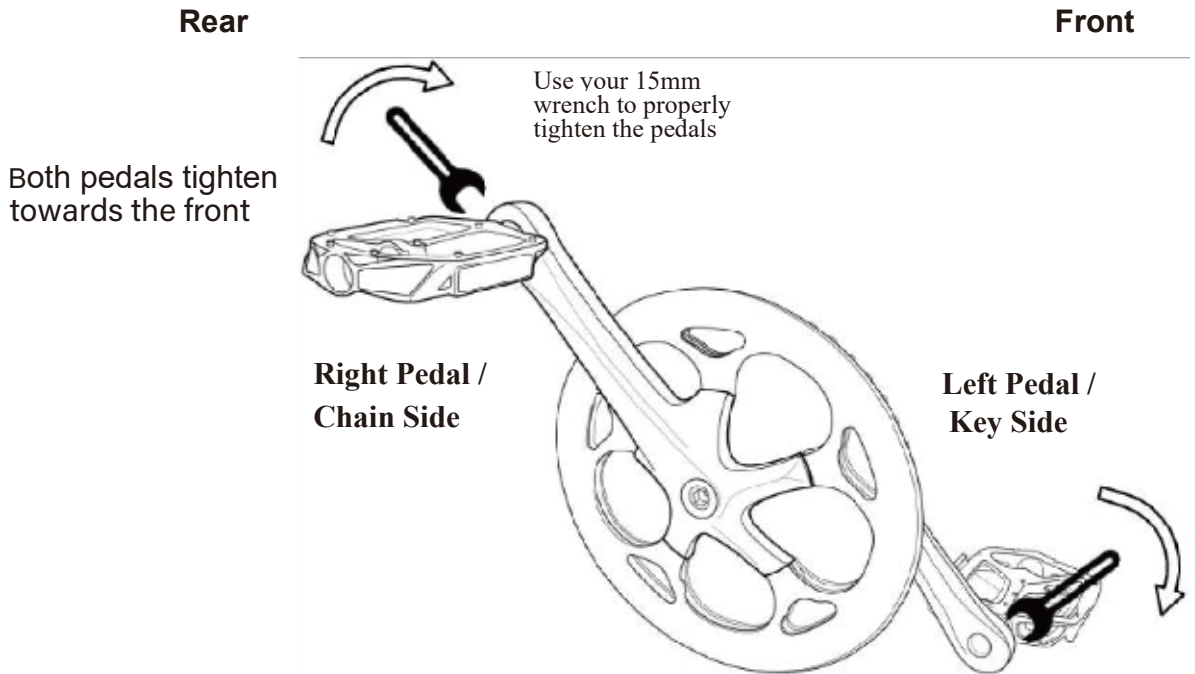



Remove the battery

For your convenience, the battery can be removed.

1



1.Insert the key and turn clockwise.

2



2.Press the silver button at the same time.

3



3. Use your hand to take the battery off.



Charge Your E-Bike

Before using the electric bike, you must fully charge the battery.

1



1.Remove the rubber cover on the charging port and charge the battery directly.

2



2.Charge the battery off the bike.

3



3.Plug the charger into a power outlet, charging should be initiated and will be indicated by the LED charge status lights on the charger. When the light turns red, it means the battery was now charging. Please make sure to connect the battery first and then connect the wall outlet.

4



4.Once the battery is fully charged, the charging indicator light will turn green. Unplug the charger from the wall outlet first and then remove the charger output end from the battery charging port.

Folding the bike

1



1. Locate middle of the bike

2



2. Find this quick release.

3



3. Push forward and open the latch.

4



4. Fold the bike.

5



5. Hook the button upward and open the latch

6





6. Bike is totally folded.



Start-Up Procedure

After the bike has been properly assembled according to the assembly video, all components are secured correctly, a certified, reputable mechanic has checked the assembly, and you have read this ensure manual, turn on the bike and select a pedal assist level following the steps below:

1. Use NFC to swipe the card or enter the password: 1212 and turn on the bike
2. Turn on the front light if needed or desired. Once the battery is on, long press  button.
3. Select the desired level of pedal assistance (PAS) between level 0 through 5 using the  and  on the display controller. Level 1 corresponds to the lowest level of pedal assistance, and level 5 corresponds to the highest level of pedal assistance. Level 0 indicates pedal assistance is inactive. Start in PAS level 0 or 1 and adjust from there.
4. Begin riding carefully. With the proper safety gear and rider knowledge, you may now operate your bike. On a flat surface, in a low gear (1 or 2), most riders should be able to begin pedaling the bike with pedal assist level 0 or 1. You may also use the throttle to accelerate and maintain your desired speed.
5. The throttle is used by slowly and carefully rotating the throttle backward toward the rider. Do not use the throttle unless you are on the bike.



Do not use the throttle while dismounted. Avoid accidental application of the throttle while dismounted; anytime you are moving the bike while dismounted, ensure the bike is powered off to prevent accidental application of the throttle.



Display Details

I. Overview

Low Beam Light / Cruise / USB / Brake Error / Low Battery Alert

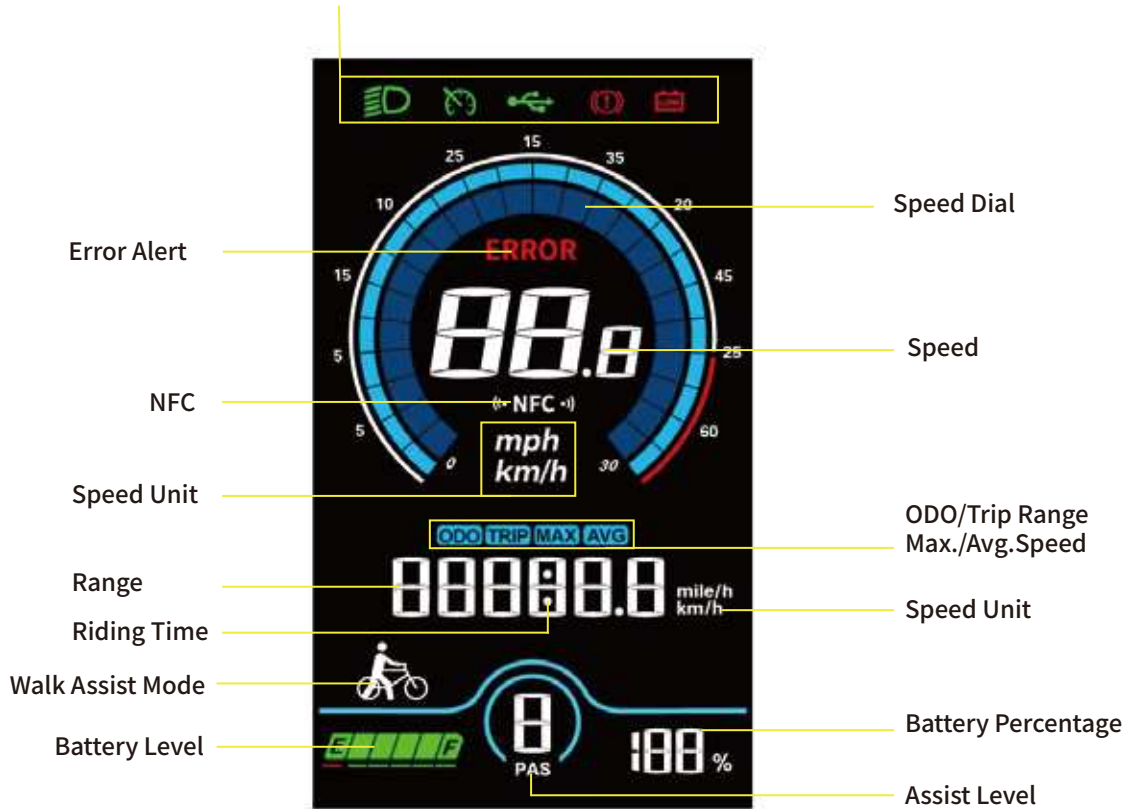

1.Specifications

- Working Voltage: DC 24V/36V/48V/60V/72V

- Working Voltage: DC 24V/36V/48V/60V/72V
- Rated Working Current: 12mA
- Leakage current: <1uA
- Screen Size: 4.0"LCD
- Communication Type: UART (by default) / CAN (optional)
- Working Temperature: -20°C ~ 60°C
- Storage Temperature: -30°C ~ 70°C
- Waterproof Rating: IP66

2. Function

- How to turn on the bike:
 1. First take out the battery and press the switch button on the battery.
 2. Use NFC to swipe the card or enter the password: 1212
- System unit switch (km/h or mph)
- Assist Level Control and Display
- Battery indication: battery level percentage, low voltage indication
- Speed display: (in km/h or mph) real-time speed (SPEED),
max speed (MAX), average speed (AVG)

- Distance: single-trip distance (TRIP), total travel distance (ODO)
- Walk assist mode
- Front light indication: front light status supported by controller.
- Error code indication
- Riding Info: Braking Status, Front Light Status, Cruise, Low Voltage.

II. Operation

1. Display Interface

1.1 Riding Interface

- Status: Real-time Riding Status: Front Light, Brake, Low Voltage, Turning, Cruise, Drive Status, etc.
- Battery Status: Residual Battery Percentage
- Multi-Function Section: ODO (total range), TRIP (single ride range), MAX (max. speed), AVG (average speed), TIME (riding time), VOL (battery voltage), Wh (motor power), CUR (current), etc.

2 Error Interface

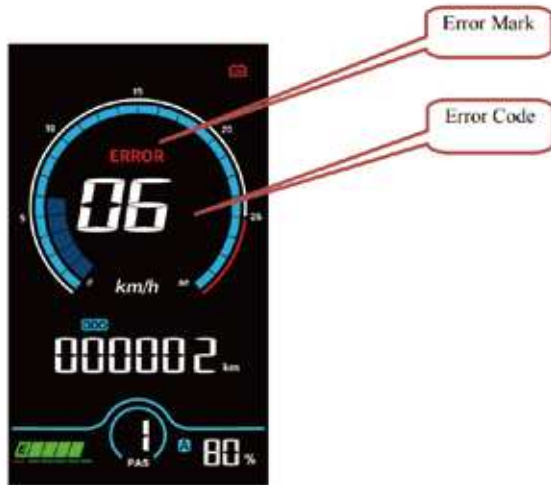

In the above interface: Error Indicator: ERROR, Error Code: 06

3. Key Pad





There are 5 keys on the keypad, in the following instructions:
is called Plus Key;



is called On/Off Key;



is called Minus/Walk Assist Key;



is called Light Key;



is called Info Key

4. Key Operation

Key operation guide as follows:

Press and Hold: means press and hold the key(s) for more than 2s.

Press: means press the key(s) for less than 0.5s.

Double Tap: means double tap the key(s) within 0.3s

4.1 On/Off

Turn on the Display: When the display is off, press and hold the On/Off Key

to turn on the display, it will show boot interface and then enter riding interface. (If boot password is activated, enter the boot password at start).

Turn off the Display: When the display is on, press and hold the On/Off Key, the display will be turned off. If no operation is engaged for 10min (0km/h), the display will be auto-off. Auto-off time can be set in the Settings.

4.2 Assist Level

Press the Plus Key or Minus/Walk Assist Key to switch assist levels. There are 5 levels by default: 0/1/2/3/4/5. 0 means no assist power.

4.3 Toggle Displays

When the display is on, press the Info Key to toggle among ODO (total range), Trip (single trip range), TIME (riding time) etc.

4.4 Light On/Off

Turn on the Front Light: when the front light is off, press the Light Key to turn it on, and the light icon will be shown on the riding interface (to remove this functions, please reconfigure the controller).

Turn off the Front Light: when the front light is on, press the Light Key to turn it off, and the light icon will be off on the riding interface.

4.5 Walk Assist Mode

Engage Walk Assist Mode: On the riding interface, press and hold the Minus/Walk Assist Key to enter walk assist mode. Hold the Minus/Walk Assist Key to engage walk assist mode, the walk mode icon will be shown on the riding interface, the real-time speed will be shown in the speed section.

5. Error Code

Error Code (decimal)	Status	Note
E00	Normal	
E01	Reserved	
E02	Brake Error	
E03	PAS Sensor Error (Riding Mark)	Not Realized
E04	Walk Assist Mode	
E05	Real-Time Cruise	
E06	Low Voltage Protection	
E07	Motor Error	

E08	Throttle Error	
E09	Controller Error	
E10	Communications Error	
E12	BMS Communications Error	
E13	Front Light Error	

Before your first ride

1. Check all nuts, bolts, and screws are tightened. If you suspect that something is loose, do not ride your bicycle. Try to fasten them carefully. If you are not sure, take your bicycle to a bicycle repair shop for service.
2. Adjust the seat to a proper height so that your legs can be comfortably stretched.
3. Check the front and rear brakes to see whether they are working correctly.
4. Fully charge the battery.
5. Pay attention to your first acceleration.

The acceleration of your Freesky eBike may be faster than anticipated, and may feel unusual at first. Before your first ride, you should use the lowest level of pedal assist (PAS 1) and become familiar with the operation of your eBike by practicing starting, stopping, cornering, and navigating obstacles in a safe environment away from other bicycles, pedestrians, and/or vehicles. You should also pay particular attention to terrain conditions as you may approach obstacles faster than expected. The Pedal Assist may be activated as soon as you step onto the pedals and the bicycle is in motion. ALWAYS be seated on the bicycle and engage at least one brake before starting to pedal. DO NOT place one foot on a pedal then throw your other leg over the bicycle or your eBike could accelerate unexpectedly.

6. When using throttle, try to push slowly to get a moderate speed and then push to the end to get the maximum speed. If you push the throttle hard at the beginning, the acceleration of your Freesky eBike may be faster than anticipated, which may cause the bike to lose control.
7. ALWAYS apply even pressure to both brake levers when slowing down or stopping. If only the front brake is applied while slowing or stopping quickly, you may be ejected over the front handlebars.

Daily Care and Maintenance

Cleaning and Storage

If you see stains on the bike body, wipe them off with a damp cloth. If the stains won't scrub off, put on some toothpaste, and brush them with a tooth brush, then wipe them off with a damp cloth.

Notes: do not clean the bike with alcohol, gasoline, kerosene or other corrosive and volatile chemical solvents to prevent dire damage. Do not wash the bike is with a high-pressure water spray. During cleaning, make sure that the bike turned off, the charging cable is unplugged, and the rubber flap is closed as water leakage may result in electric shock or other major problems. When the bike is not in use, keep it indoors where it is dry and cool. Do not put it outdoors for along time. Excessive sunlight, overheating and over cooling accelerate the battery pack's life span.

Battery Storage

Charge the battery pack before and during storage. When the battery pack will not be used for weeks or months, remove it from the eBike and store the battery pack at about 60 % charge as indicated by the Energy Bar on the display. At about 60% charge, the battery will degrade less, compared to higher charge levels. Every 2-3 months check the battery charge level and recharge to 60%, if necessary.

Note: If the battery is stored with no charge for an extended period of time, it may be damaged despite the low self-discharge and may reduce the battery capacity. For optimum service life for your battery pack, charge the battery pack to 100% a few hours before you plan to ride. If possible, store the battery pack in a dry, well-ventilated place. Protect it from moisture and water. For an optimum service life, store your Freesky eBike battery at temperatures between 50° F and 68° F. Never store it at temperatures below 14° F or above 140° F. Make sure the maximum storage temperature is not exceeded. Do not leave

the battery in your car during the summer, for example, and store it away from direct sunlight.

NOTE: Leaving the battery installed on the bicycle for long-term storage is not recommended.

Battery Disposal

When your battery is no longer usable, dispose of your battery according to state and federal regulations. State regulations regarding battery disposal vary so it is important you find out and follow the rules in your state. Lithium Ion batteries cannot be put in with standard garbage bins.

Recommended Service Intervals

Regular inspection and maintenance are key to ensure bikes from Freesky function as intended, and to reduce wear and tear on their systems. Recommended service intervals are meant to be used as guidelines. Real world wear and tear, and the need for service, will vary with condition of use. We generally recommend inspections, service, and necessary replacements be performed at the time or mileage interval that comes first in the following table.

Interval	Inspect	Service	Replace
Weekly, 100-200 miles (160-321 km)	<ul style="list-style-type: none"> - Check drivetrain for proper alignment and function (including the chain, freewheel, chainring, and derailleur). - Check wheel trueness and for quiet wheel operation (without spoke noise). - Check condition of frame for any damage. 	<ul style="list-style-type: none"> - Clean frame by wiping frame down with damp cloth. - Use barrel adjuster(s) to tension derailleur/brake cables if needed. 	<ul style="list-style-type: none"> - Replace any components confirmed by Freesky, Product Support or a certified, reputable bike mechanic.
Monthly, 250-750 miles (402-1207 km)	<ul style="list-style-type: none"> - Check bike is shifting properly, proper derailleur cable tension. - Check chain stretch. - Check spoke tension. - Check accessory mounting (rack mounting bolts, and alignment). 	<ul style="list-style-type: none"> - Clean and lubricate drivetrain. - Check crankset and pedal torque. - Clean brake and shift cables. - True and tension wheels if any loose spokes are discovered. - Balance the battery. 	<ul style="list-style-type: none"> - Replace brake and shift cables if necessary. - Replace brake pads if necessary.
Every 6 Months, 750-1250miles (1207-2011 km)	<ul style="list-style-type: none"> - Inspect drivetrain (chain, chainring, freewheel, and derailleur). - Inspect all cables and housings. 	<ul style="list-style-type: none"> - Standard tune-up by certified, reputable bike mechanic is recommended. - Grease bottom bracket. 	<ul style="list-style-type: none"> - Replace brake pads. - Replace tires if necessary. - Replace cables and housings if necessary.

Pre-Ride Safety Checklist

Notice: Before every ride, and after every 25-45 miles(40-72 km), we advise you following the pre-ride safety checklist.

Safety Check	
1.Brakes	<p>Ensure front and rear brakes work properly.</p> <p>Check brake pads for wear and ensure they are not overworn.</p> <p>Ensure brake pads are correctly positioned in relation to the rims.</p> <p>Ensure brake levers are lubricated and tightly secured to the handlebar.</p> <p>Test that the brake levers are firm and that the brake is functioning properly.</p>
2.Wheels and Tires	<p>Ensure tires are inflated within the recommended limits posted on the tire sidewalls and hold air.</p> <p>Ensure tires have good tread, have no bulges or excessive wear, and are free from any other damage.</p> <p>Ensure rims run true and have no obvious wobbles, dents, or kinks.</p> <p>Ensure all wheel spokes are tight and not broken.</p> <p>Check axle nuts and front wheel quick release to ensure they are tight. Ensure the locking lever on the quick release skewer is correctly tensioned, fully closed, and secured.</p>
3.Steering	<p>Ensure the handlebar and stem are correctly adjusted, tightened, and allow proper steering.</p> <p>Perform a handlebar twist test to ensure the stem clamp bolt security.</p> <p>Ensure the handlebar is set correctly in relation to the fork and the direction of travel</p>
4.Chain	<p>Ensure the chain is clean, oiled, and runs smoothly.</p> <p>Extra care is required in wet, salty/otherwise corrosive, or dusty conditions.</p>
5.Bearings	<p>Ensure all bearings are lubricated, run freely, and display no excess movement, grinding, or rattling.</p> <p>Check headset, wheel bearings, pedal bearings, and bottom bracket bearings.</p>
6.Cranks and Pedals	<p>Ensure pedals are securely tightened to the cranks.</p> <p>Ensure the cranks are securely tightened and are not bent.</p>
7.Derailleur and Mechanical Cables	<p>Check that the derailleur is adjusted and functioning properly.</p> <p>Ensure shifter and brake levers are attached to the handlebar securely.</p> <p>Ensure all shifter and brake cables are properly lubricated.</p>

Safety Check	
8.Frame, Fork, and Seat	<p>Check that the frame and fork are not bent or broken.</p> <p>If either frame or fork are bent or broken, they should be replaced.</p> <p>Check that the seat is adjusted properly, and seatpost quick release lever is securely tightened.</p>
9.Motor Drive Assembly and Throttle	<p>Ensure hub motor is spinning smoothly and motor bearings are in good working order.</p> <p>Ensure all power cables running to hub motor are secured and undamaged.</p> <p>Make sure the hub motor axle bolts are secured and the torque arm, torque arm bolt, and torque washers are in place.</p>
10.Battery	<p>Ensure battery is charged before use.</p> <p>Ensure there is no damage to battery.</p> <p>Lock battery to frame and ensure that it is secured.</p> <p>Charge and store bike and battery in a dry location, between 50 °F – 77 °F (10 °C – 25 °C).</p> <p>Let bike dry completely before using again.</p>
11.Electrical Cables	<p>Look over connectors to make sure they are fully seated and free from debris or moisture.</p> <p>Check cables and cable housing for obvious signs of damage.</p> <p>Ensure front light is functioning, adjusted properly, and unobstructed.</p>
12.Accessories	<p>Ensure all reflectors are properly fitted and not obscured.</p> <p>Ensure all other fittings on bike are properly secured and functioning.</p> <p>Inspect helmet and other safety gear for signs of damage.</p> <p>Ensure rider is wearing a helmet and other required riding safety gear.</p> <p>Ensure mounting hardware is properly secured if fitted with a front rack, rear rack, basket, etc.</p> <p>Ensure the taillight and taillight power wire are properly secured if fitted with rear rack.</p> <p>Ensure the fender mounting hardware is properly secured if fitted with fenders.</p> <p>Ensure there are no cracks or holes in fenders.</p> <p>If installed, ensure the optional rear wheel lock is secured in the unlocked position and the key is removed before every ride.</p>



Your cables, spokes, and chain will stretch after an initial break-in period of 50-100 mi (80-160 km), and bolted connections can loosen. Always have a certified, reputable bike mechanic perform a tune-up on your bike after your initial break-in period of 50-100 mi (80-160 km) (depending on riding conditions such as total weight, riding characteristics, and terrain). Regular inspections and tune-ups are particularly important for ensuring that your bike remains safe and fun to ride.

Tire Inflation and Replacement

The Boulevard employs 20"×4"rubber tires with inner tubes. The tires are designed for durability and safety for regular cycling activities and need to be checked before each use for proper inflation and condition. Proper inflation, care, and timely replacement will help ensure that your bike's operational characteristics will be maintained, and unsafe conditions avoided.

Freesky recommends 16-20 PSI for the stock tires. Always stay within the manufacturer's recommended air pressure range as listed on the tire sidewall.



It is critically important that proper air pressure is always maintained in pneumatic tires. Do not underinflate or overinflate your tires. Low pressure may result in loss of control, and overinflated tires may burst. Failure to always maintain the air pressure rating indicated on pneumatic tires may result in tire and/or wheel failure.



Inflate your tires from a regulated air source with an available pressure gauge. Inflating your tires from an unregulated air source could overinflate them, resulting in a burst tire.

Even tires equipped with built-in, flat-preventative tire liners, like those that come with bikes from Freesky, can and do get flats from punctures, pinches, impact, and other causes. When tire wear becomes evident or a flat tire is discovered, tires and/or tubes must be replaced before operating the bike or injury to operators and/or damage to your bike from Freesky could occur.



When changing a tire or tube, ensure that all air pressure has been removed from the inner tube prior to removing the tire from the rim. Failure to remove all air pressure from the inner tube could result in serious injury.



Using aftermarket tires or inner tubes, not provided by Freesky may void your warranty, create an unsafe riding condition, or damage to your bike. If required by law, ensure replacement aftermarket tires have sufficient reflective sidewall striping.

For more information on tire or tube replacement procedures, or questions about tire inflation, contact Freesky after-sale service at support@freeskycycle.com.

Troubleshooting

	Symptoms	Possible Causes	Most Common Solutions
1	The bike does not work	<ol style="list-style-type: none"> 1. Insufficient battery power 2. Faulty connections 3. Battery not fully seated in tray 4. Improper turn on sequence 5. Brakes are applied 6. Blown discharge fuse 	<ol style="list-style-type: none"> 1. Charge the battery 2. Clean and repair connectors 3. Install battery correctly 4. Turn on bike with proper sequence 5. Disengage brakes 6. Replace discharge fuse
2	Irregular acceleration and/or reduced top speed	<ol style="list-style-type: none"> 1. Insufficient battery power 2. Loose or damaged throttle 3. Misaligned or damaged magnet ring 	<ol style="list-style-type: none"> 1. Charge or replace battery 2. Replace throttle 3. Align or replace magnet ring
3	The motor does not respond when the bike is powered on	<ol style="list-style-type: none"> 1. Loose wiring 2. Loose or damaged throttle 3. Loose or damaged motor plug wire 4. Damaged motor 	<ol style="list-style-type: none"> 1. Repair and or reconnect 2. Tighten or replace 3. Secure or replace 4. Repair or replace
4	Reduced range	<ol style="list-style-type: none"> 1. Low tire pressure 2. Low or faulty battery 3. Driving with too many hills, headwind, braking, and/or excessive load 4. Battery discharged for long period of time without regular charges, aged, damaged, or unbalanced 5. Brakes rubbing 	<ol style="list-style-type: none"> 1. Adjust tire pressure 2. Check connections or charge battery 3. Assist with pedals or adjust route 4. Balance the battery; contact Tech Support if range decline persists 5. Adjust the brakes
5	The battery will not charge	<ol style="list-style-type: none"> 1. Charger not well connected 2. Charger damaged 3. Battery damaged 4. Wiring damaged 5. Blown charge fuse 	<ol style="list-style-type: none"> 1. Adjust the connections 2. Replace 3. Replace 4. Repair or replace 5. Replace charge fuse
6	Wheel or motor makes strange noises	<ol style="list-style-type: none"> 1. Loose or damaged wheel spokes or rim 2. Loose or damaged motor wiring 	<ol style="list-style-type: none"> 1. Tighten, repair, or replace 2. Reconnect or replace motor.

Specifications

ITEM	SPECIFICATIONS
Model	Boulevard
Product Dimensions	175×63×122(cm)
Package Dimensions	146×30×72(cm)
Max Load	300 lbs(135kg)
Package Weight	88lbs (40kg)
E Bike Weight	75 lbs (34kg)
Battery/Charger	Input 100-240V 50/60HZ AC Plug; Output 54.6V 3A
Range	Range 45-80 miles
Charging Time	4-6 hours
Tire Pressure	16-20 PSI
Recommended Rider Heights	5'1"-5'11"
Frame Material	Artificial Mechanics 6061 Aluminum Alloy Frame
IP Level	Ip65

FAQS

Q: What if the e-bike arrived missing accessory or broken part?

A: Please take a photo and send to Freesky Support Team by sending email: support@freeskycycle.com and Freesky Support Team will reply you soon and send correct accessory or part replacement.

Q: Will my bike arrive assembled?

A: Your bike will arrive mostly assembled. We' ll also provide the tools and a comprehensive assembly video for the rest part.

Q: What can I do if something goes wrong with my e-bike during the warranty?

A: We believe that communication is the best way to solve the problem. Please contact us in time. To help you solve the problem as quickly as possible, please describe the problem in detail and provide photos/videos with your order ID.

Warranty

The warranty is non-transferable and only applies to the original owner. This warranty gives you specific rights and purchasers may also have other rights, which may vary from state to state. Damage caused by failing to follow instructions in the manual, acts of God, accident, misuse, neglect, abuse, commercial use, alterations, modification, improper assembly, installation of parts or accessories not originally intended or compatible with the Freesky eBike as sold, operator error, water damage, extreme riding, stunt riding, or improper follow-up maintenance is not covered under this warranty.

Warranty parts will only be shipped within the continental United States.

Parts covered by the warranty: frame, forks, stem, handlebars, headset, seat post, saddle, brakes (excluding brake pads), lights, bottom bracket, crank set, pedals, rims, wheel hub, freewheel, cassette, derailleur, shifter, motor, throttle, controller, wiring harness, display (excluding damage due to water), kickstand, reflectors, and hardware. The battery warranty does not include damage from power surges, use of 3rd party charger, improper maintenance or other such misuse, normal wear, or water damage (including rust).

Accessories sold on freeskycycle.com are not covered under warranty. Stolen bikes are not covered under warranty.

Necessary precautions must be taken to ensure the bike and battery are not exposed to severe weather conditions. Exposure to very wet, hot, or cold conditions may void the warranty.

Freesky eBikes will replace any parts deemed to have been damaged during shipping. Shipping damage must be reported to Freesky eBikes within 7 days of shipment arrival.

This applies to all products, including bikes and accessories. You will NOT be refunded as compensation for your time or efforts replacing damaged parts.

Replacement parts will not be sent until photographic evidence has been provided to

Freesky eBikes. Freesky eBikes may request additional documentation (such as video) to assist with accurately diagnosing the problem and processing the warranty claim.

Most warranty parts will be fulfilled in 5 business days after the request is put into our system by a customer service representative. Warranty parts will be sent from our American warehouse if stock is available, or we will ship from China factory, where the shipping time takes around 2 weeks. Warranty parts will not be expedited.

Items including the chain, tires, wheels, rims, tubes, battery handle, brake rotors, brake pads, cables and housings, grips, and spokes are considered wear items. These items wear down with normal use and are not covered under warranty. You are responsible for replacing and maintaining these wear items.

Any unauthorized alterations or repairs are not covered and may void this warranty.

For warranty services, please contact Freesky ebike's online support by email at support@freeskycycle.com. Bikes or parts returned without proper documentation may result in delayed service or denied warranty coverage. Warranty return shipping costs along with duties and taxes are the responsibility of the claimant. All unauthorized returns will be refused.

Note that your insurance policies may not provide coverage for accidents involving Freesky eBikes. To determine if coverage is provided, you should contact your insurance company or agent.

Damage as a result of an accident is not covered under this warranty, and Freesky eBikes is not responsible for repair or replacement of damaged bikes or parts.

Freesky eBikes reserves the right to change its warranty at any time and without notice. Any action, lawsuit or other proceeding, under this warranty or otherwise related to the bike must be commenced within ninety (90) days after expiration of the one-year warranty period.

Bike Performance Disclaimer

The bikes listed range and top speed are estimates (not guarantees) of expected performance. Performance will vary with rider weight, cargo weight, rider/cargo shape (both contribute to drag), terrain, tire pressure, brake adjustment, throttle & PAS usage, pedal power, battery charge level, ambient temperature, and wind conditions.

Under certain conditions it is possible to get ranges and top speeds that are different from the listed estimates.

To get the maximum range out of each battery charge, there are some simple things you can do:

- Ride at a lower PAS level
- Use lower PAS levels and pedal when climbing hills
- Pedal when starting from a standstill

Liability Disclaimer

Riding any kind of bicycle comes with inherent risks and dangers that cannot be predicted or avoided. These dangers could result in a serious accident, injury, or death of the rider. It is the sole responsibility of the rider to become properly educated and prepared to ride safely. Once in possession of the bike, Freesky eBikes strongly encourages and recommends that all customers have a certified and reputable bicycle mechanic complete a full inspection of each component on the bicycle to ensure it is safe for operation.

Freesky eBikes makes no claims or guarantees that the brakes, battery, frame, motor, motor controller, display, electrical cables, electrical cable housings, fasteners, grips, fork, stem, shifters, headset, seat post, seat post clamp, handlebar stem clamp, saddle, wheel hubs, handlebars, spokes, rims, tires, tubes, derailleur, freewheel, cassette, throttle, kickstand, lights, reflectors, hardware, bottom bracket, or any other part or accessory, will be properly secured and adjusted upon arrival. Before every ride, fully inspect your bicycle to ensure everything is secured and adjusted properly. Under no circumstances is Freesky eBikes responsible for any damage resulting from damaged, defective, or improperly secured parts. This includes, but is not limited to, damage to personal property, personal injury, or death.

Refund Policy

PARTS DAMAGE

Ebikes from Freesky may experience some damages because of long-time transportation, such as the screw bent or reflector broken. Send us pictures immediately after you get the item. After approval, we will send you replacement parts or partial refund upon agreement.

EBIKE RETURNS

Ebikes from Freesky are under 15-day return policy, which means you have 15 days after receiving your item to request a return. To return an ebike that is not defective or damaged, please contact the customer service team within 15 days. We do not provide product returns service after 15 days, as same as refund.

Please make sure the following if you need to return the bike:

- 1. The mileage on the LCD screen of the ebike must be less than 10 miles.**
- 2. There should be no wear, dirt, scratches, fragrances, or any other signs of use.**
- 3. All items (charger, keys, hardware, etc.) received by the customer must be included in the original packaging (all cardboard and foam) and in the same condition.**

You will be responsible for paying the shipping costs for returning your item under this condition. Original and return shipping costs are nonrefundable, and we do charge a restocking fee up to 25% of order value for the return. Return shipping fees may vary depending upon the chosen freight carrier. Customers are responsible for arranging return shipping and paying any fees. We recommend using a trackable shipping service and purchasing shipping insurance.

Before a return is sent, the customer must have written approval of said return from Freesky. If a customer sends a return without the written consent of Freesky, a refund will not be issued and the customer will have to pay for shipping to get the item returned, or sacrifice the item. Once we received the item, we will conduct a detailed inspection on the package, then we will either replace the item or give you a partial refund according to the actual condition of the

item we received. This will be issued in 2-5 business days.

For ebike that has been delivered for more than 15 days or used for more than 10 miles, if there is any problem, we do not accept returns anymore, only repairs and replacements are allowed.

LATE OR MISSING REFUNDS

If you haven't received a refund after 5 business days of approval, please check your bank account again and contact your credit card company/bank as it may take some time before your refund is officially posted. There is often some processing time before a refund is posted. If you've done all of this and you still have not received your refund, please contact us at service @freeskycycle.com.



FREESKY

go anywhere